

2450



24" HORIZONTAL BEAM OPTICAL COMPARATOR

- **"55 Years"**
Manufacturing Experience in U.S.A.
- **"Heavy Duty"**
Steel Construction
- **"Exclusive"**
Gothic-Arch Bearings
- **"Superior"**
Optics-Brightness-Resolution
- **"Large"**
8" X 12" Stage Travel
- **Standard**
Stepper Motor Drive with Joystick Controls
- **Erect Image**

S-T  **INDUSTRIES, INC.**
SCHERR-TUMICO

*See the
Quality*

24" COMPARATOR The "2450" Series 24" Erect Image Horizontal Beam Optical Comparator features a more rugged structure, a 8" x 12" travel measuring stage and a 3-position lens turret. Over 55 years experience manufacturing optical comparators in the U.S., combined with its worldwide service organization makes S-T Optical Comparators your best buy.

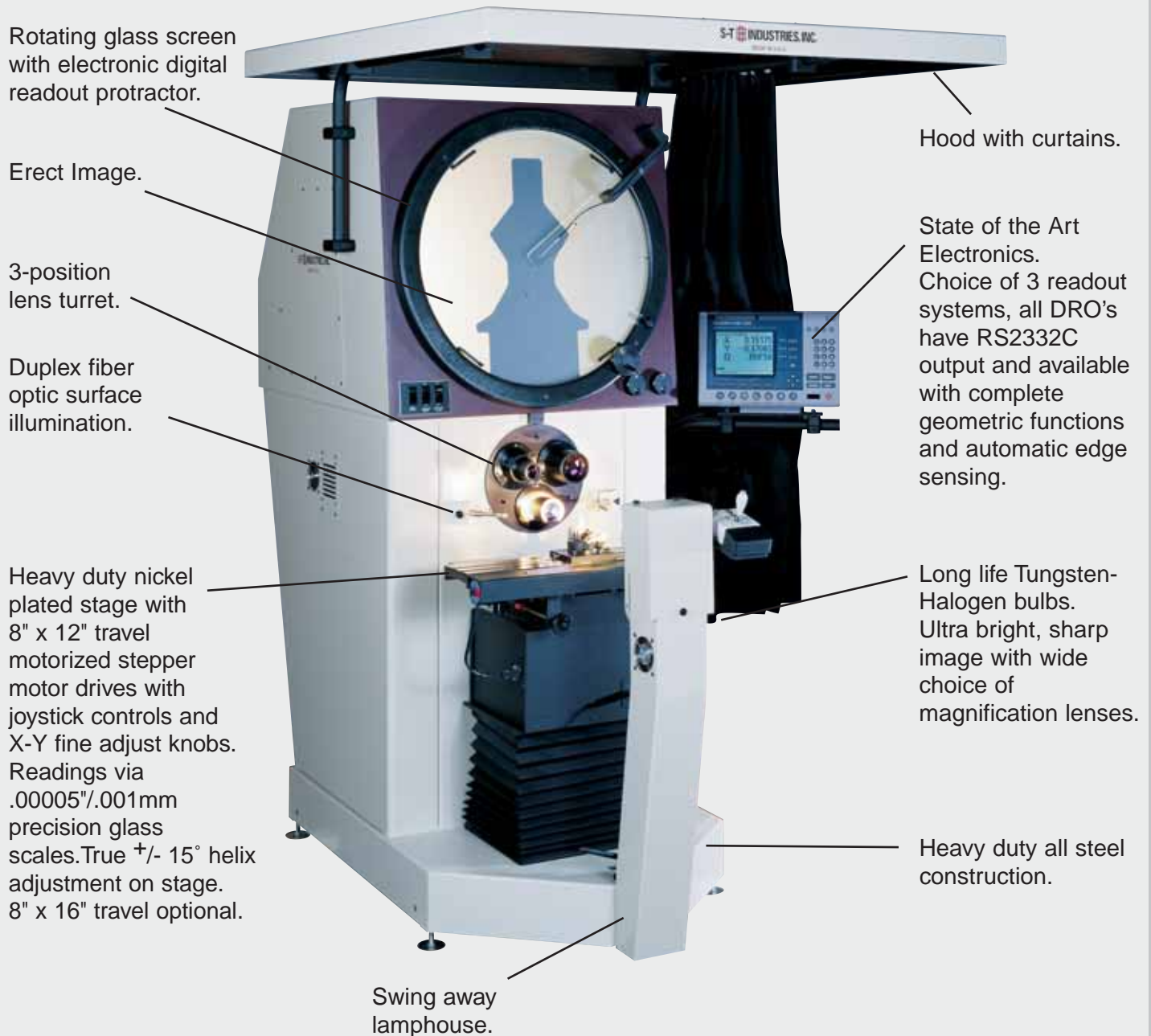

STANDARD FEATURES



Nickle plated 5" X 24" top plate with 2 std. clamping slots, 8" (Y) x 12" (X), travel with a 200 lb. work load capacity, exclusive gothic arch bearing ways, .00005"/.001mm Acu-Rite glass scales, motorized stepper motor drive on X and Y axis with variable speed joystick controller with X and Y axis fine adjust jog wheels. True +/- 15° helix adjustment on stage in 5 min. increments. Swing away lamphouse allows you to inspect extra long parts. Rotating glass screen with chart clips and digital readout protractor and duplex high intensity surface illumination.

DIGITAL READOUTS

Quadra-Chek 221 and 221E



These powerful digital readouts provide fast geometric computations in a simple, easy to use format. Functions include point, line, circle, distance, angle, skew alignment and Measure Magic. Other features include Inch/MM, Cartesian/Polar, nearest/farthest distance, complimentary angles, serial and parallel ports and 200-feature memory. Large, high contrast LCD screen graphically displays measurement features and construction. Housing tilts backward or forward for best angle of operation. Model 221E includes fiber optic edge sensor.



Standard Digital Readout

The Standard digital readout features absolute/incremental, IN/MM conversion, random zeroing, RS232C output, linear error compensation and Q axis for digital screen protractor.



Quadra-Chek 4215

PC computer based geometric readout system, mouse driven, with on screen graphic representation of part or part segment as it is measured. Simple CAD interface simplifies constructions and part programming. Unlimited part and feature memory. Includes computer with Microsoft® Windows® fiber optic edge sensor and all functions found in the Quadra-Chek 200.

2450

FEATURES & SPECIFICATIONS

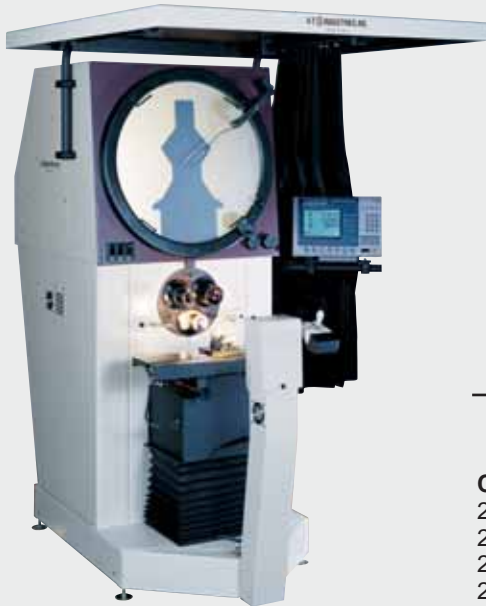

CATALOG #	DESCRIPTION
20-2450-01	with S-T 7000 DRO
20-2450-02	with QC 221 DRO
20-2450-03	with QC 221E DRO, Edge Sensing
20-2450-05	with QC 4215 DRO, Edge Sensing

NOTE: the "2450" Series is also available with full CNC controls

OPTIONS

CATALOG #	DESCRIPTION	CATALOG #	DESCRIPTION
20-1320-00	5 x Lens	20-1318-00	50 x Lens
20-1310-00	10 x Lens	20-1319-00	62½ x Lens
20-1313-00	20 x Lens	20-1321-00	100 x Lens
20-1315-00	25 x Lens		
20-1316-00	31¼ x Lens		

NOTE: 2450 shown above with lamphouse tilted to the right.

SPECIFICATIONS

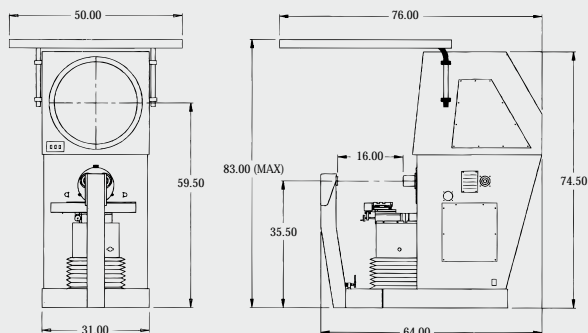

Work Table: 5" x 24" (125 x 600 mm)
Measuring Range: 8" x 12" (200 x 300 mm)
Allowable Work Load on Stage: 200 lbs. (90 kg)
Illumination: Profile - 150w, Surface - 150w x 2
Focus Travel: 3" (75 mm)
Screen Size: 24" (600 mm)
Floor Space: 31" x 64" (785 x 1625 mm)
Electrical: 100-240v, 50/60hz
Weight: 1000 lbs. (455 kg) - Crated 1200 lbs. (545 kg)

THE S-T FAMILY OF OPTICAL COMPARATORS

14" HORIZONTAL



20-3500



20-3700

30"



22-5600

16" HORIZONTAL



20-1600

14" VERTICAL



20-4600

CALL OR WRITE TODAY FOR FREE INFORMATION ON ANY OF THE ABOVE



Manufacturers of SCHERR-TUMICO Precision Measuring Tools
 301 Armstrong Boulevard North
 St. James, Minnesota 56081-0517
 Phone: 1-800-326-2039 • (507) 375-3211
 FAX 507-375-4503
 E-Mail: rjf-st@prairie.lakes.com
 Internet: www.thomasregister.com/stindustries
 stindustries.com



International Operations

SCHERR-TUMICO optical comparators and video inspection systems are available throughout the industrialized world. S-T Industries maintains a service and distribution network with factory qualified sales and service representatives in the following countries. Call or write for your representative.

Australia	Canada	France	Germany	Great Britain
Greece	Holland	Hong Kong	India	Indonesia
Israel	Italy	Malaysia	Mexico	New Zealand
Norway	Singapore	South Africa	South America	South Korea
Spain	Sweden	Taiwan	Thailand	Turkey