

3700



NEW "3700" SERIES



14" ERECT IMAGE HORIZONTAL BEAM OPTICAL COMPARATOR

- "ERECT" Image
- "Exclusive" Gothic Arch Bearings
- Heavy Duty Steel Construction
- Large, 6" x 12" Stage Travel
- Optional, Stepper Motor Drive, CNC Control
- Two Lens Turret
- Swing Away Lamphouse

S-T  **INDUSTRIES, INC.**
SCHERR - TUMICO

See ^{the} Quality

"3700" SERIES 14" COMPARATOR The NEW 3700 Series 14" Horizontal Beam Optical Comparator combines the ease of use, rigidity and accuracy. Over 60 years of experience manufacturing Optical Comparators in the U.S.A., combined with its worldwide factory trained service organization, makes S-T Optical Comparators your best buy in the industry.

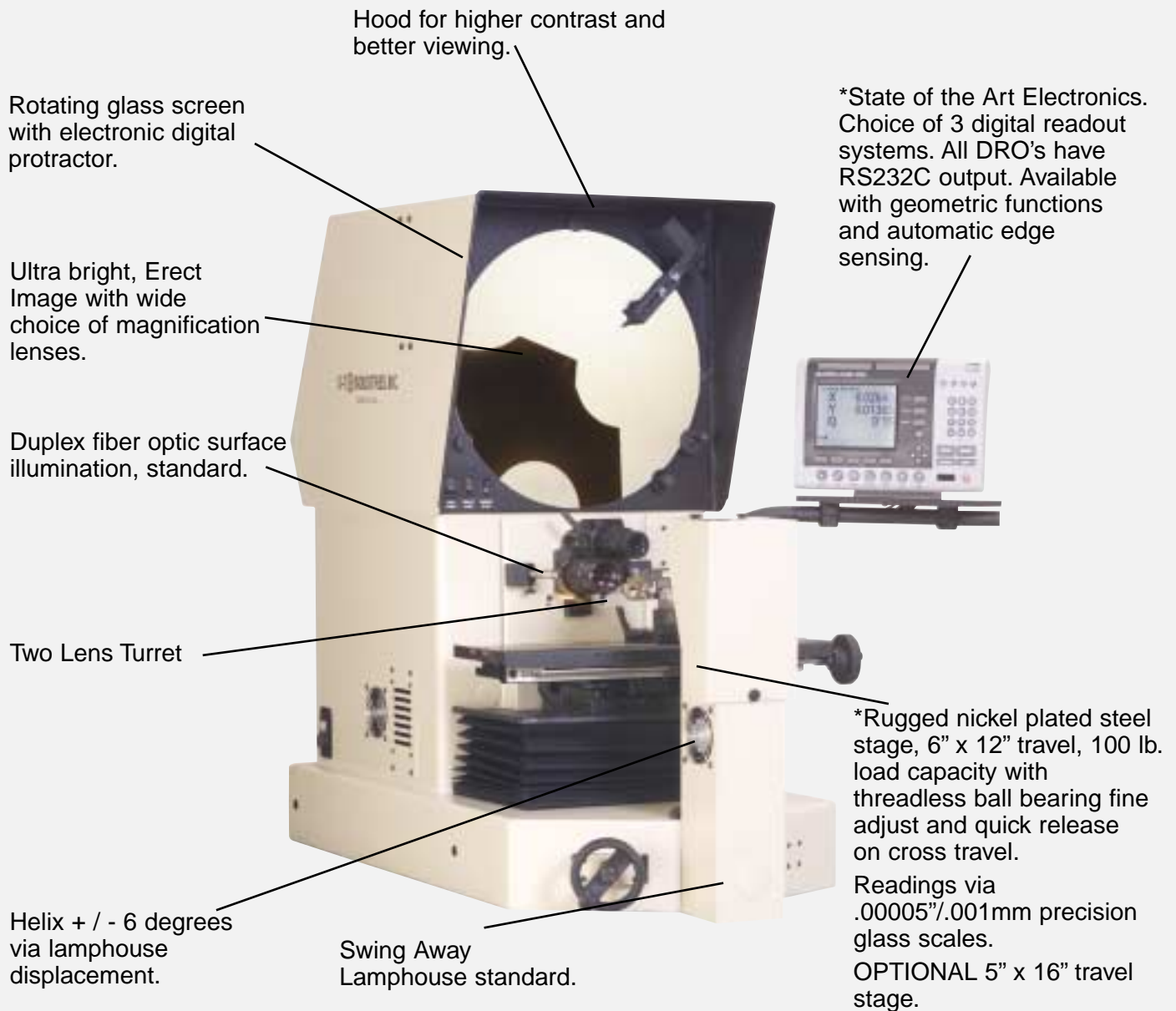

*NOTE: "3788" Series CNC 14" Optical Comparator. The "3788" has all of the fine features of the standard "3700" 14" comparator **PLUS** the benefit of high-speed stepper motor drives and CNC positioning. Simple, yet powerful part programming and optical edge sensing convert the optical comparator into a fully automated inspection system.

STANDARD FEATURES



"New" standard Two Lens Turret Lens System for use with all lens except the 5x and 31 1/4x. The 5x and 31 1/4x lens fit in lens holder, however, cannot be rotated. "New" standard Swing Away Lamphouse.

The "3700" series optical comparator comes equipped with a heavy duty, high precision measuring stage with the following standard features:

- * 5" x 20" nickel plated top plate, hardened steel
- * 2 std. clamping slots
- * 6" (Y) x 12" (X) travel (opt. 5" x 16" travel)
- * 100 lb. load capacity with exclusive gothic arch ball-ways
- * .00005"/.001mm ACURITE glass scales
- * Horizontal travel via handwheel with quick release and fine adjust
- * Helix capability +/- 6 degrees via lamphouse displacement

Optional Power Drive Systems

- * Stepper drive system. Includes 2-axis joystick and fine adjust jog wheels for micro fine adjustment. Available with all DRO options.
- * CNC control stepper drive system. Includes 2-axis joystick and fine adjust jog wheels for micro fine adjustment. Includes Quadra-Chek 4215.

All S-T Industries Optical Comparators and Video Inspection systems include a two year warranty on parts and labor, installation and training at your facility and a certificate to NIST. There are no additional hidden costs for this service.

DIGITAL READOUTS



Quadra-Chek 221 and 221E

These powerful digital readouts provide fast geometric computations in a simple, easy to use format. Functions include point, line, circle, distance, angle, skew alignment and Measure Magic. Other features include Inch/MM, Cartesian/Polar, nearest/farthest distance, complimentary angles, serial and parallel ports and 200-feature memory. Large, high contrast LCD screen graphically displays measurement features and construction. Housing tilts backward or forward for best angle of operation. Model 221E includes fiber optic edge sensor.



Standard Digital Readout

The Standard digital readout features absolute/incremental, IN/MM conversion, random zeroing, RS232C output, linear error compensation and Q axis for digital screen protractor.



Quadra-Chek 4215

PC computer based geometric readout system, mouse driven, with on screen graphic representation of part or part segment as it is measured. Simple CAD interface simplifies constructions and part programming. Unlimited part and feature memory. Includes computer with Microsoft® Windows® fiber optic edge sensor and all functions found in the Quadra-Chek 200.

3700

FEATURES & SPECIFICATIONS



Shown above, 20-3700-03 on Heavy Duty Console Base and with Lamphouse tilted to one side.

CATALOG NO.	DESCRIPTION
20-3700-01	14" Optical Comparator w/ST-7000 DRO
20-3700-02	14" Optical Comparator w/QC-221 DRO
20-3700-03	14" Optical Comparator w/QC-221E DRO
20-3700-05	14" Optical Comparator w/QC-4215 DRO
20-3788-01	14" CNC Optical Comparator w/QC-4215 DRO

OPTIONS

20-0320-01	5 x Lens	20-0317-00	3 1/4 x Lens
20-0310-00	10 x Lens	20-0318-00	50 x Lens
20-0312-00	20 x Lens	20-0319-00	62 1/2 x Lens
20-0313-00	20 x Lens	20-0321-01	100 x Lens
20-1406-01	Heavy Duty Console Base - 22" x 38" x 35" high		

NOTE: A variety of staging fixtures also available.

SPECIFICATIONS

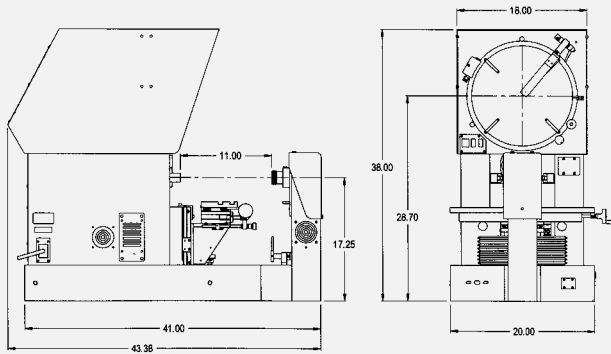

Work Table – 5" x 20" (125 x 500 mm) w/2 clamping slots
Measuring Travel – 12" (300 mm) (X), 6" (150 mm) (Y), 2.5" (60 mm) Focus

Optional 16" Horiz. Travel

Measuring Stage Resolution – .00005"/.001mm
Allowable Work Load – 100 Lbs. (45 kg)

Two Lens Turret

Digital Screen Protractor – 1 min/.01 Deg arc

Duplex Surface Illumination

Helix Angle – +/- 6 Deg by Lamphouse

14" Frosted Glass Screen w/30, 60, 90 Deg Lines

115/220 volts 50/60 hz

Weight: Net 325 lbs. (145 kg) - Crated 356 lbs. (160 kg)

THE S-T FAMILY OF OPTICAL COMPARATORS

14" HORIZONTAL

24" HORIZONTAL

30"

16" HORIZONTAL

14" VERTICAL



20-3500



20-2450



22-5600



20-1600



20-4600

CALL OR WRITE TODAY FOR FREE INFORMATION ON ANY OF THE ABOVE

ST INDUSTRIES, INC.

Manufacturers of SCHERR-TUMICO Precision Measuring Tools

301 Armstrong Boulevard North

St. James, Minnesota 56081-0517

Phone: 1-800-326-2039 • (507) 375-3211

FAX 507-375-4503

E-Mail: sales@stindustries.com

www.stindustries.com

Form #40-0471-00

10-03



International Operations

SCHERR-TUMICO optical comparators and video inspection systems are available throughout the industrialized world. S-T Industries maintains a service and distribution network with factory qualified sales and service representatives in the following countries. Call or write for your representative.

Australia	Canada	France	Germany	Great Britain
Greece	Holland	Hong Kong	India	Indonesia
Israel	Italy	Malaysia	Mexico	New Zealand
Norway	Singapore	South Africa	South America	South Korea
Spain	Sweden	Taiwan	Thailand	Turkey